



DanceDanceRevolution X

Operator's Manual

For parts or service, contact your local distributor, or:

**Betson Enterprises
303 Paterson Plank Road
Carlstadt, New Jersey 07072-2307**



**Main Phone: (201) 438-1300
Toll Free Phone: (800) 524-2343
Part Phone: (800) 828-2048**

Product Specifications

ELECTRICAL POWER

Domestic	120 VAC @ 60 Hz, 5 amps
International Users	230 VAC @ 50 Hz, 2.5 amps

DC POWER FUSE GUIDE

+5 VDC 3 AMP Slow Blow
+12 VDC 7 AMP Slow Blow

TEMPERATURE

32° F to 100° F
(0° C to 38° C)

HUMIDITY

Must not exceed 95% relative humidity.

CABINET DIMENSIONS

Height = 85.5 in. (2.17 m)
Depth = 70.5 in. (1.79 m)
Width = 80.0 in. (2.03 m)

CABINET SHIPPING DIMENSIONS

Height = 68.5 in. (1.74 m)
Depth = 58 in. (1.47 m)
Width = 45.0 in. (1.14 m)

Weight (Shipping) = 800 lbs. (362.87 kg)

- Failure to properly operate this machine could result in malfunction or accident, so please read this manual carefully before commencing operation. Be sure to install and operate the machine as described in this manual.
- It requires two individuals to safely setup the top box.
- If the machine fails to function correctly, immediately turn off the machine and contact your local distributor or authorized service agent.

INSPECTION AND INSTALLATION

WARNING: Use extreme care when moving or servicing the game cabinet. Don't plug in the game until you have read this manual. Notify your distributor if shipping crate is damaged during transit. Do not discard shipping box and wooden pallet until the game has been properly installed and full functionality has been verified.

UNBOXING THE GAME:

1. Move the crate to a safe working area. Area must be well lit and has enough clearance to allow free and unobstructed movement around the game. Floor must be level and free of debris. Avoid carpeted or potentially slippery floors.
2. Begin by removing the banding which runs vertically across the box and secures the game to the pallet. Remove the top cover.
3. Carefully lift the box over the game. Take care as contents may have shifted or become loose.



4. Remove the banding which secures the dance floors on each side of the cabinet.



5. Carefully remove the two dance floors, the box spacer and the box containing joiner assemblies.



Spacer Box

Joiner Box

Dance Floors

6. Remove the plastic cover from the monitor cabinet and carefully slide the monitor cabinet off the wooden pallet. This operation requires two individuals. Exercise extreme care as the monitor cabinet is top heavy at this stage of assembly.

7. Remove the coin door keys from the coin return tray. Open the coin door and remove keys for cash box. Find the "hardware bag" which contains the following:



Quantity	Description
2	¼ x 20 x 2" Hex Bolt
2	lock washer
2	flat washer
8	¼ x 20 x 1 ¼" Hex Bolt
8	lock washer
8	lock washer
8	flat washer
12	¾" x 10-32" Philips head screw

8. The following tools are needed to finish installation:

1. 7/16" Hex Nut Driver
2. Philips Head Screw Driver
3. ¼" Nut Driver

Note: The above tools are not shipped with the game.

INSTALLING THE TOP BOX:

Important Safety Note: For safety reasons, the top box must be secured as described before continuing with game setup. Installing the top box requires two individuals.

1. Make sure the monitor cabinet is level and set on a flat surface.
2. Raise the top box to its upright position.



3. Remove six screws using a 1/4" nut driver from the back cover behind the top box. Remove the back cover to access the top box mounting holes.

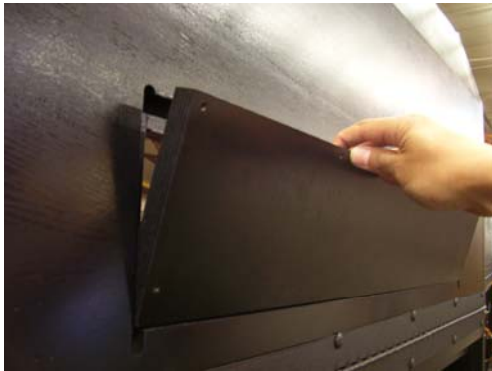

4. Secure the top box in the upright position using two 1/4 x 20 x 2" bolts (lock washer and flat washer). There is one mounting hole each on the left and right side of the top box.



Inside Top Box: Left Side



Inside Top Box: Right Side

5. Re-install Top Box back cover.

Dance Floor Assembly:

1. Locate the box containing the joiner assemblies and remove contents. Inspect for possible damage.

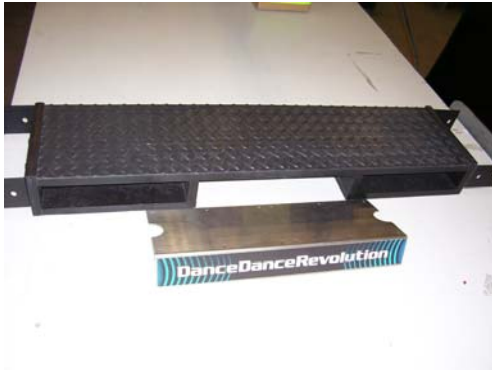

2. Move the dance floor side by side. Inspect for possible damage.



3. Place the metal joiner bracket between the two player supports. Secure using twelve(12) stainless steel screws.



4. Lower the leg levelers such so that they are making contact with the floor but not load bearing.

Note: Do not step on the dance floor at this time. It is not yet fully secure and may move or become unstable!

Mating Dance Floor to Monitor Assembly:

Important Safety Note: Final installation should be done on flat stable surface only. Please take viewers and normal foot traffic into consideration when choosing a site for your DDRX machine. All leg levelers must be lowered fully before game is put into operation. Access to the back of the back should be limited to service personnel only.

1. Position the dance floor approximately 10" (25 cm) from the monitor cabinet.



2. Route the two wire harnesses from the dance floor and into the wire access way at the center of the monitor cabinet.

3. Connect to mating connectors in the monitor cabinet side. Remove back door to access connectors. Use wire colors to match connectors correctly.

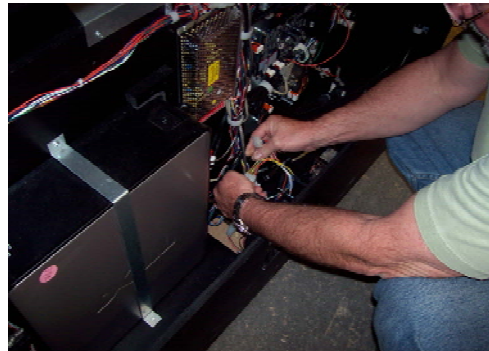

4. Place the wooden joiner assembly between the monitor cabinet and the dance floor. Take care to check that the wires are not crushed. It does not matter which side the joiner is facing.
5. Secure the dance floor to the monitor using eight (8) ¼ x 20 x 1 ¼ hex bolts(lock washers, flat washers). Tighten ALL eight(8) bolts on each side of the dance floor.



Final Preparation and Inspection:

Important Safety Note: Use only line cord shipped with the game. Do not use AC cheater plugs or adaptors for this game. Consult with your service agent if you have any questions regarding unique AC connections.

1. Remove all protective plastic covering from the dance floor and the monitor cabinet.
2. Make sure the dance floor is secured and stable.
3. Make sure the player supports are secured and stable.
3. Check to make sure that all mounting hardware are tight.
4. Check player accessible areas for sharp edges.
5. Find the line cord in the cash box and connect to the AC inlet plate behind the game.
6. Check to make sure that wall outlet is properly fused and wired per your local electrical safety code.
7. Make sure the DDRX power switch is on the OFF position.
8. Plug the line cord into the AC outlet and turn the switch to ON position.
9. The game should display the attract mode in approximately 3-5 minutes.
10. Press the Test button inside the coin door and verify that all I/O, switches, lights and sound are operational. See the DDRX Operator's Manual for details on this step.

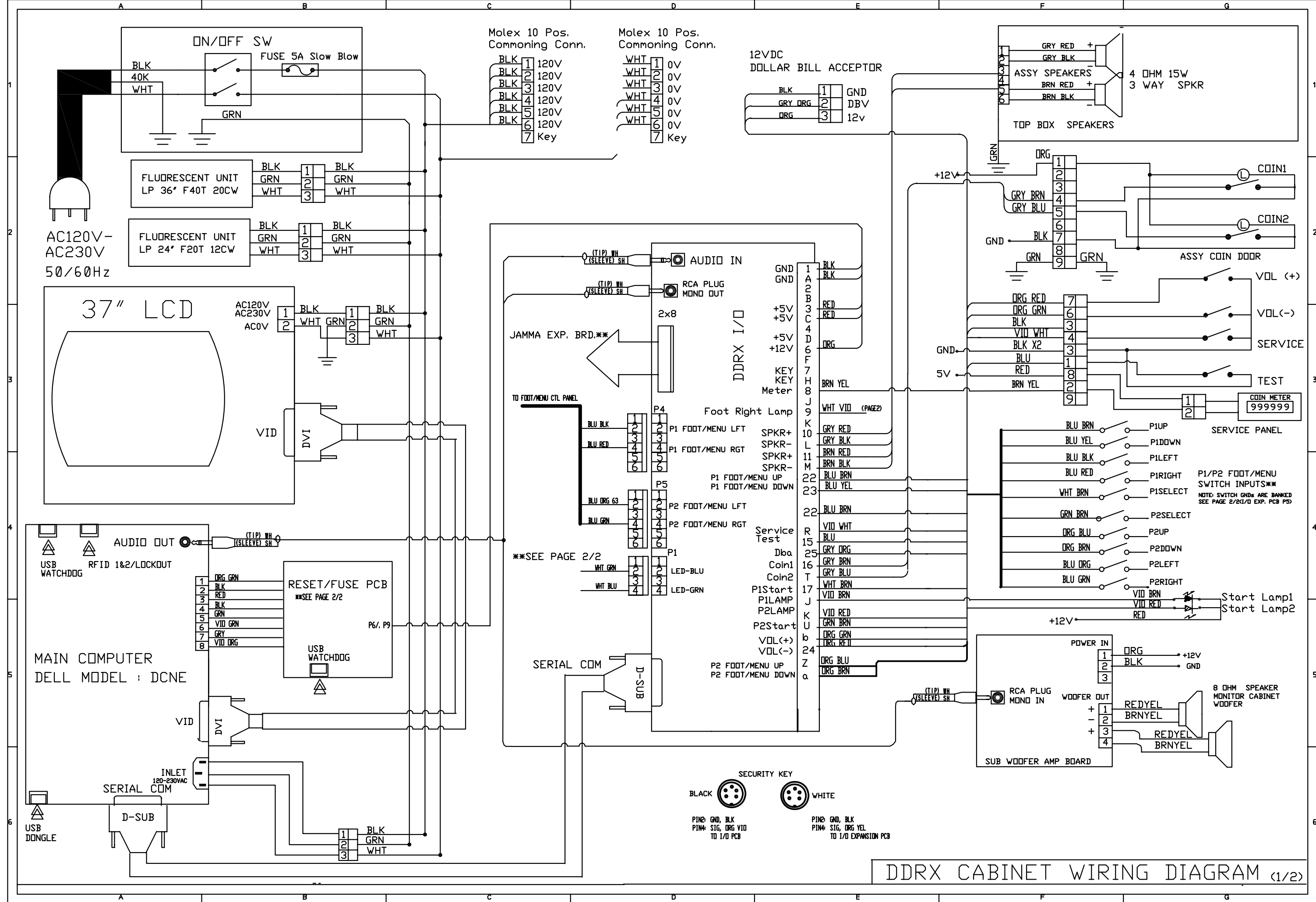

DDR CABINET WIRING DIAGRAM (1/2)

JAMMA I/O EXP. PCB.**

FUSE/WATCHDOG PCB

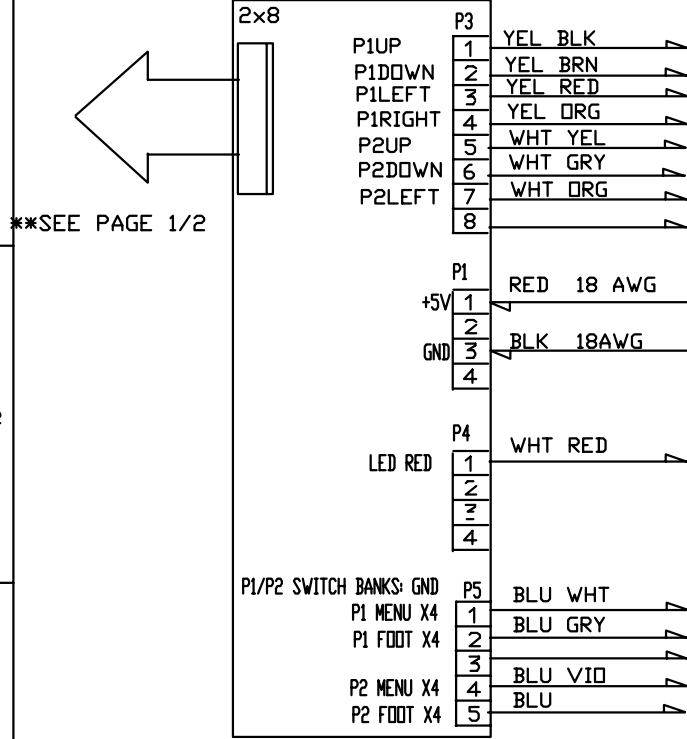

DELL OPTIPLEX 740 PC

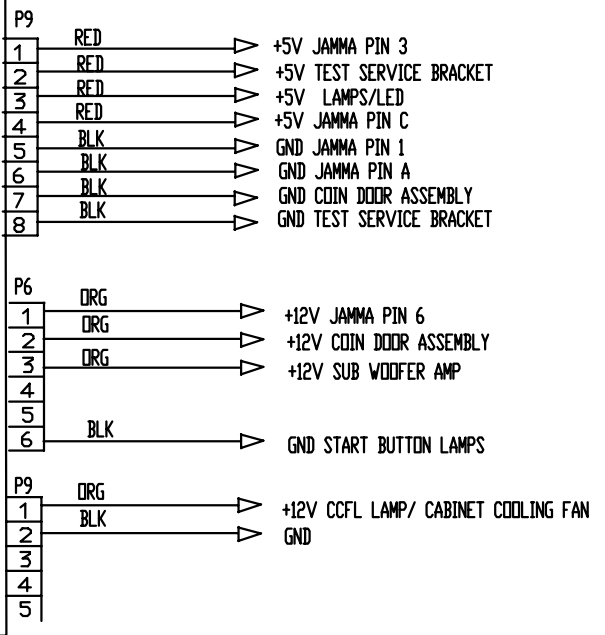
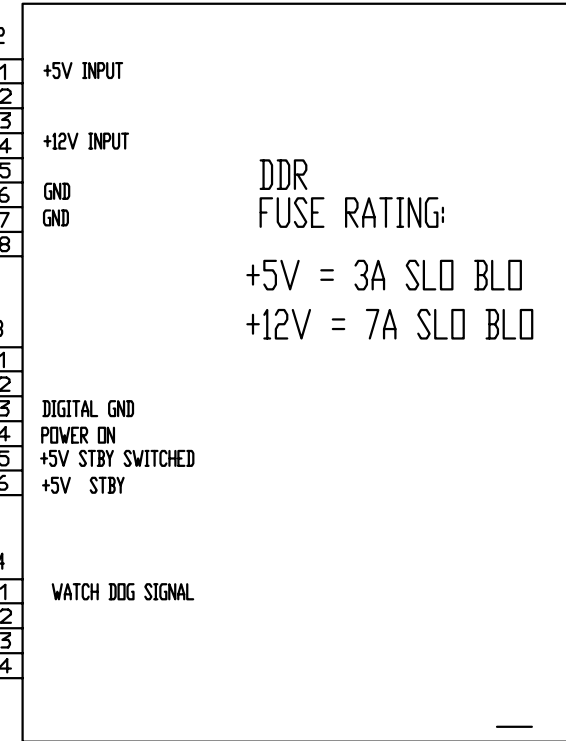
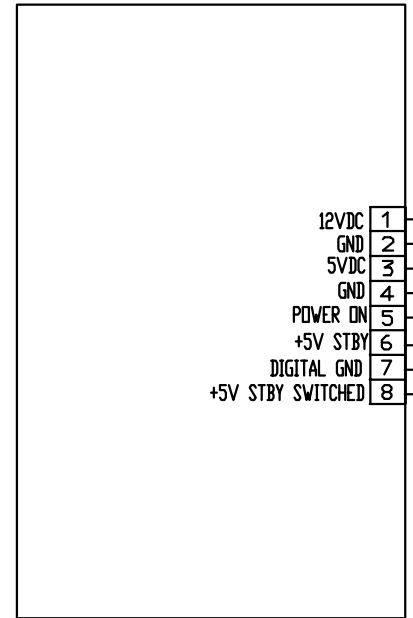

USB PWM PCB

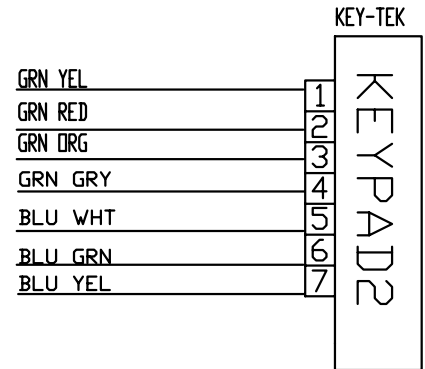
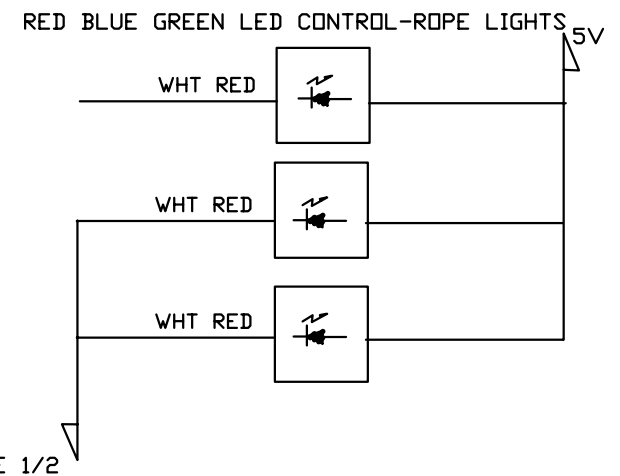
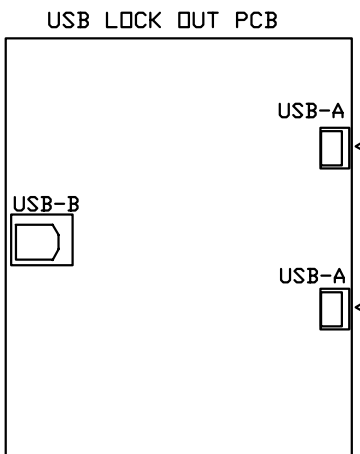
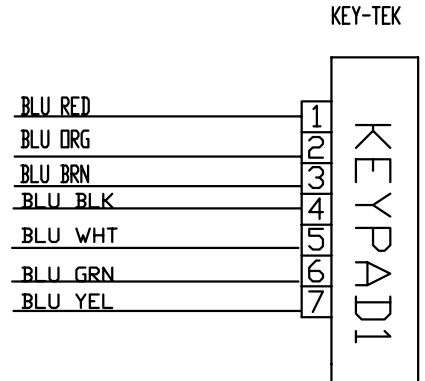
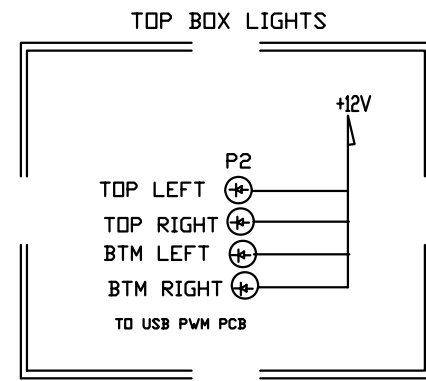
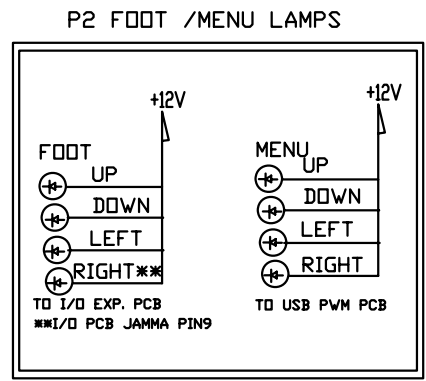
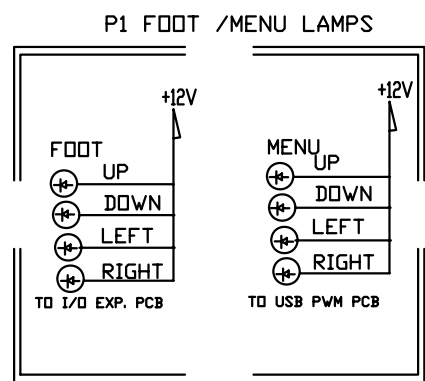
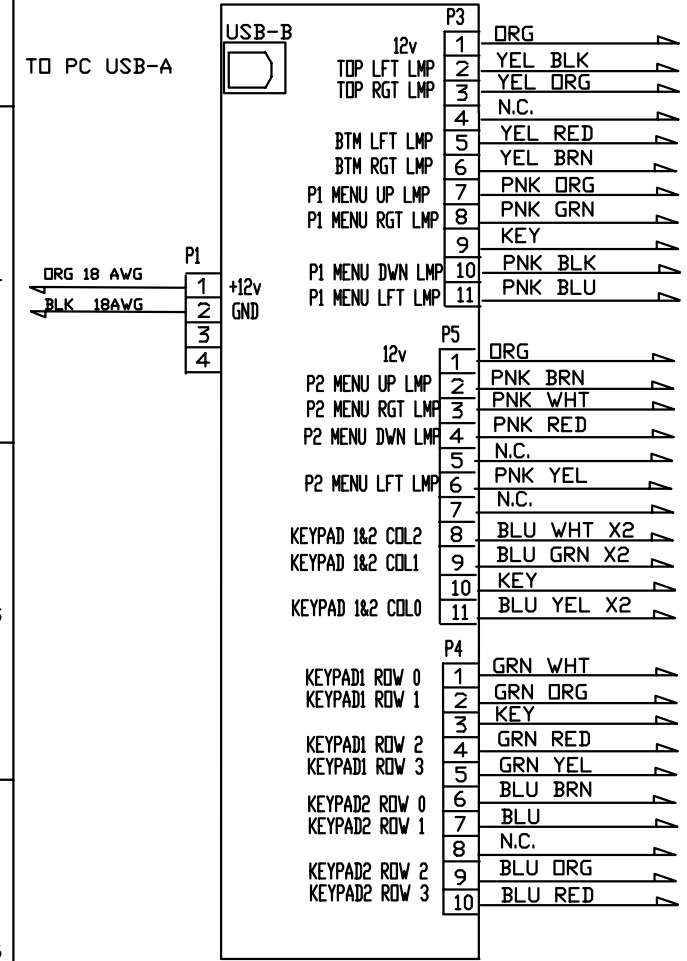

**SEE PAGE 1/2

Description	Part Number	Qty
CABINET MONITOR DDR X	23-371-00	1
ASSEMBLY TEST SERVICE - BBHP	AP-407	1
METER/COUNTER 5V/6VDC 1W 7DIGIT	8-560	1
ASSEMBLY KIT HARDWARE DDR X	AS-2011	1
LINE CORD SJT 8'2" LG. NEMA 5-15 TO 1EC-320	8-582	1
MANUAL DDR X	90-12-585	1
ASSEMBLY PLASTIC MOLDING & SPEAKER	AS-1985	1
PLASTIC INJECTION MOLDED FAKE SPEAKER	90-4-218	1
SPEAKER 6.5" WOOFER 8 OHMS	30-116	1
SPEAKER GRILL DOMED (GUITAR HERO)	1-1501	1
LED LIGHT STRIP SPEAKER ASSY (GUITAR HERO)	90-8-254	1
PCB WATCHDOG - 3/7 AMP (SAFARI DELUXE)	90-19-266	1
PCB I/O BOARD - DDR X	90-19-241-2	1
PCB USB-PWM DDR X	90-19-286-1	1
PCB SUB-WOOFER AMP SUPERBIKES	90-19-251	1
PCB USB LOCKOUT BOARD DDR X	90-19-294	1
PCB I/O EXPANSION (DDR X)	90-19-276-1	1
BRACKET DUAL DIN FOR DALLAS KEYS	1-1559	1
FAN 12 VOLT DC 120 X 120 X 25 MM GRYPHON	8-594	1
ASSY AC LINE IN - BBHP	AS-1863	1
ASSEMBLY CONTROL PANEL DDR X	AS-2013	1
BRACKET CONTROL PANEL DDR X	1-1519	1
ASSEMBLY BUTTON & SWITCH TRIANGLE RED 12V	AP-405	1
ASSEMBLY BUTTON & SWITCH SQUARE GREEN 12V	AP-406	1
PCB LED - BLUE (GUITAR HERO)	90-19-275-BLU	2
PCB LED - RED (GUITAR HERO)	90-19-275-RED	2
PCB LED - YELLOW (GUITAR HERO)	90-19-275-YEL	2
PCB LED - GREEN (GUITAR HERO)	90-19-275-GRN	2
MARQUEE PLASTIC DDR X	13-207	1
ASSEMBLY STAGE CORNER LEFT DDR X	AS-2038	1
BRACKET DANCE FLOOR CORNER LEFT DDR X	1-1512	1
DECAL DANCE STAGE LEFT CORNER SET DDR X	13-217	1
ASSEMBLY STAGE COVER FRONT LEFT DDR X	AS-2042	1
BRACKET DANCE FLOOR CENTER DDR X	1-1514	1
DECAL DANCE STAGE FRONT LEFT DDR X	13-214	1
DECAL MARQUEE CABINET LEFT SIDE DDR X	13-210-L	1
DECAL MARQUEE CABINET RIGHT SIDE DDR X	13-210-R	1
DECAL MAIN CABINET LEFT SIDE DDR X	13-211-L	1
DECAL MAIN CABINET RIGHT SIDE DDR X	13-211-R	1
DECAL MAIN CABINET SPEAKER PANEL DDR X	13-212	2